



GENERAL FEATURES

- Rack dimensions: **40x40 cm**
- Net weight: 38 Kg
- Wash cycles / racks per hour: 90"-120"-180"-9' / 40-30-20-7
- Stainless-steel wash/rinse arms easily removable
- Wash pump: 330 W
- Boiler capacity: 3 lt
- Tank capacity: 12 lt
- Boiler heating element: 2,7 kW
- Tank heating element: 2,4 kW
- Water quantity per cycle: 2 lt
- Useful washing height: 290 mm
- Electronic management with 6-character LED display showing boiler and tank temperatures, multicoloured start button and self-diagnostic system
- Electric rinse aid dispenser
- Backflow prevention device
- Thermostop function (hot rinse)
- Green function for energy saving
- Automatic end of day self-cleaning cycle

WATER FILTRATION

- Pre-filtering of the tank water by means of Composite material filter
- Plastic wash pump filter, easily removable

BODY

- AISI 304 stainless-steel structure
- Partial double skinned body
- Preformed wash tank with rounded corners to avoid grime build-up
- Preformed rack guides
- Double walled door
- 30/10 door reinforcement brackets for extra strength
- Boiler in stainless-steel AISI 304

STANDARD EQUIPMENT

- 2 glass racks 40x40 cm
- 1 cutlery holders
- 1 insert for 12 saucers
- 1 inlet hose (length 2 mt)
- 1 drain hose (length 2,5 mt)

OPTIONS

- Round basket equipment (RB)
- Built-in automatic water softener (S)
- Electric detergent dispenser (DD)
- Drain pump (DP)
- Cold rinse + Drain pump (CR DP)
- KIT high feet (95÷140mm)
- KIT booster pump
- 380-415V3N~50 Hz version
- 60 Hz version

WATER TREATMENT ACCESSORIES

- Automatic water softener

ACCESSORIES

- Stainless steel stand H 550 mm
- Special racks

WATER SUPPLY CONNECTION

- **Water supply hardness:**
Water hardness between 0 and 14°f (0 ÷ 8°d)
Above 14°f (8°d) suggested water softener
- **Water supply dynamic pressure:**
Standard between 2 and 5 BAR
With built-in water softener between 2 and 4 BAR
- **Water supply temperature:**
Standard between 10 and 60°C
With built-in water softener between 10 and 25°C

MAIN POWER SUPPLY

- The voltage of main power supply must be compatible with the rated voltage
- The machine must be connected to a suitable earth (ground) system
- Connect the machine power socket to the multi-pole wall switch provided

TECHNICAL SPECIFICATIONS

- Electrical supply: **220-240V~ 50 Hz**
- Total power: **3,03 kW**
- Absorbed current: **14 A**
- Power cord supply size: **3 x 2,5 mm²**

AF 40.30 ESI LS

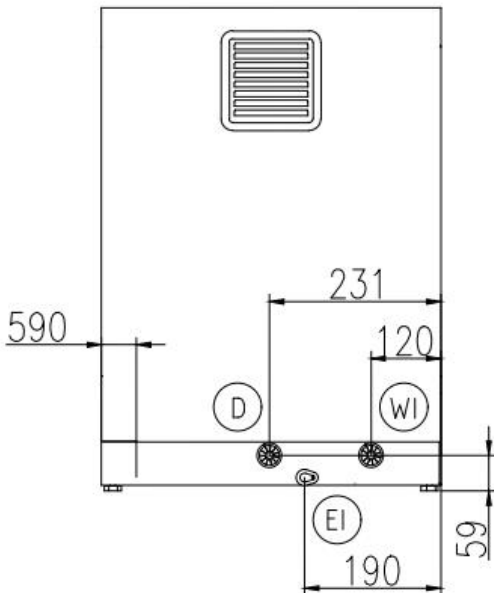
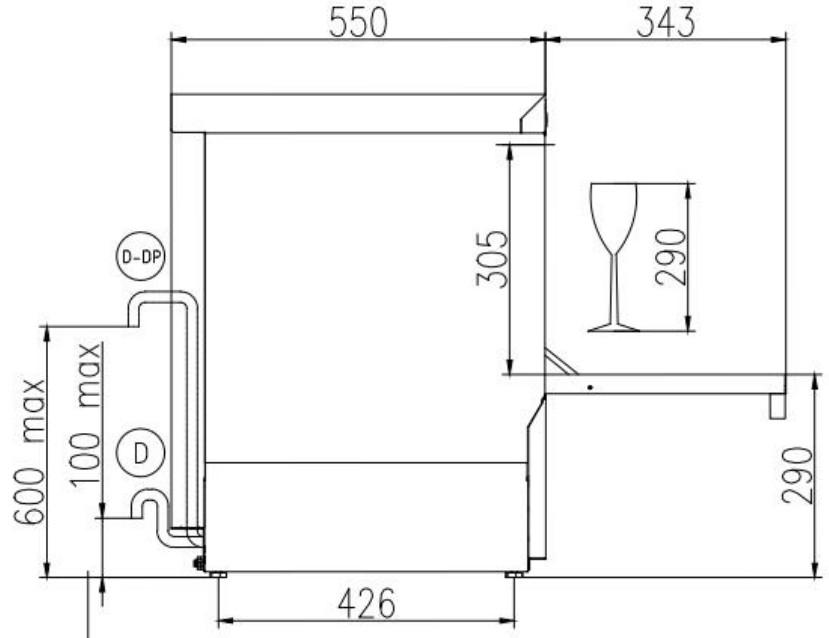
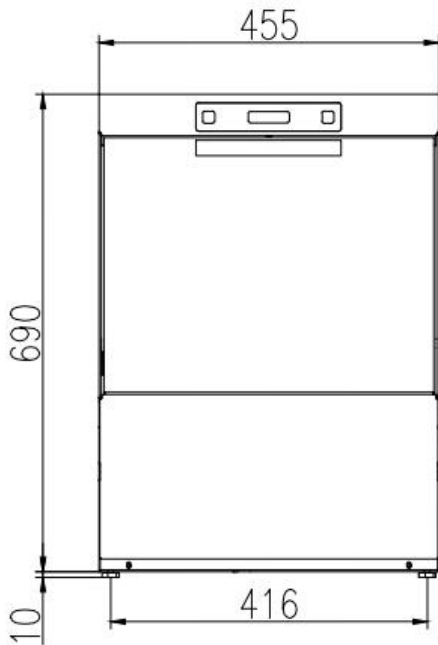

- EI CAVO DI ALIMENTAZIONE
 POWER CORD SUPPLY
 CABLE D'ALIMENTATION
 CABLE DE ALIMENTACION

- WI CANNA DI CARICO G 3/4 L=2000 mm
 G 3/4 INLET HOSE L=2000 mm
 TUYAU D'ALIMENTATION G 3/4" L=2000 mm
 TUBO DE ALIMENTACION G 3/4" L=2000 mm

- D TUBO DI SCARICO ø 29 mm L=2500 mm
 DRAIN HOSE ø 29 mm L=2500 mm
 TUYAU DE VIDANGE ø 29 mm L=2500 mm
 TUBO DE DESAGUE ø 29 mm L=2500 mm

- D-DP TUBO DI SCARICO ø 29 mm L=2500 mm (CON POMPA SCARICO)
 DRAIN HOSE ø 29 mm L=2500 mm (WITH DRAIN PUMP)
 TUYAU DE VIDANGE ø 29 mm L=2500 mm (AVEC POMPE DE VIDANGE)
 TUBO DE DESAGUE ø 29 mm L=2500 mm (CON POMPA DE DESAGUE)

	Min 10°C-MAX 60°C
	Min 10°C-MAX 25°C with energy recovery and water softner
	200:500kPa(2:5 Bar)
	100:500kPa(1:5 Bar) with atmospheric boiler
	HARDNESS 5 ÷ 14°f - 2.8 ÷ 8°d